

목록

aks17_datasheet_230621.....	1
aks17_instructions_221215.....	8

## AKS17

### Absolute Magnetic Sensing Head

With the AKS17 and associated scales, BOGEN offers cost-efficient absolute magnetic measuring solutions for all industrial applications where movements have to be measured. AKS17 can be used for linear measurements up to 3 m in length and for rotary measurements - radial and axial - from 102 mm up to 988 mm in diameter. The sensing head offers BISS-C or SSI as output as well as a parallel incremental signal output. With a resolution of 21 - 24 bits, this hollow shaft encoder outperforms typical shaft end applications many times over. With dimensions of 28 mm length, 16 mm width and a height of 6.6 mm (Molex version) or 3.4 mm (FFC version), the AKS17 is very compact. IP67 protection class enables use even in harsh environments.

Absolute  
Measuring

Rotary  
Linear  
Applications

ALWAYS  
ABSOLUTE

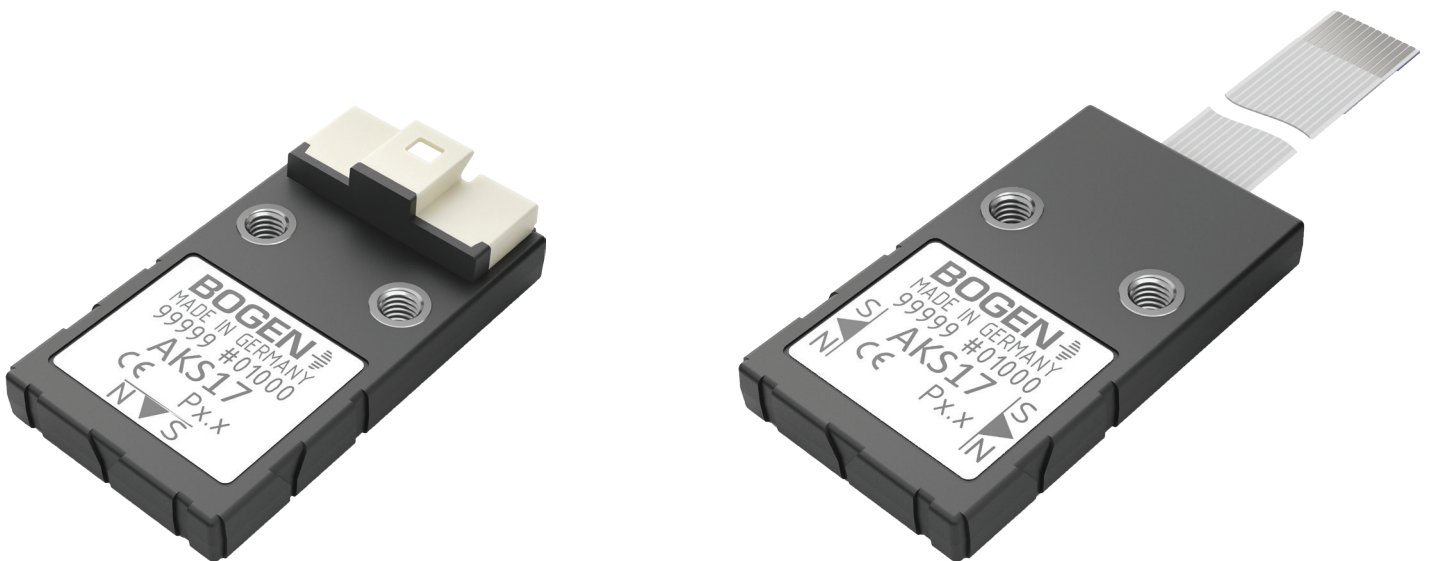

## Features and Benefits

- 21 to 24 bit absolute resolution
- 18 bit incremental resolution
- small dimensions for space-saving implementation
- resistant against contamination, vibrations, temperature, fluctuations, humidity
- no wear from usage
- corresponding scales in various diameters and lengths

## Features

absolute resolution	21 bit/22 bit/23 bit/24 bit	
commutation signal	value between 1 and 16 pole pairs (UVW)	
rotation speed	resolution (bit)	rpm
	21	up to 3,000
	22	up to 1,500
	23	up to 750
optimal distance: magnetic target $\leftrightarrow$ sensing head	24	up to 375
	pole pitch (mm)	distance (mm)
	1.28	0.4
	1.50	0.5
supply voltage	5 V $\pm$ 5 %	
maximum output load	50 mA per Channel	
energy consumption (without load)	< 120 mA $\pm$ 5 % (V+ = 5,0 V)	
LED	green LED = device on red LED = bad set up (adjustment required)	
operating temperature	- 40 to + 100 °C	
storage temperature	- 40 to + 80 °C	
protection class	IP67 (with FFC connector)	
output signals	ABZ, UZW, STEP, CW/CCW	
signal levels	RS422 ( $\pm$ 5 V)	
ABZ Incremental resolution	value between 4 and 262144 in steps of 4; ABZ signal period length Z: 90°	
weight	ca. 2.8 g	
pole pitch	1.28 or 1.50 mm	

## Signals BiSS

signals	clock (MA+, MA-) data (SLO+, SLO-)
protocol	BiSS-C BP3 encoder profile
multiturn	on special request; please contact our sales staff
timeout $t_{tos}$	150-380 ns
permissible clock period $t_{MAS}$	up to 5 MHz (200 ns)
clock signal hi level duration $t_{MASH}$	100 ns up to timeout
clock signal lo level duration $t_{MASL}$	100 ns

Timing Diagram BiSS

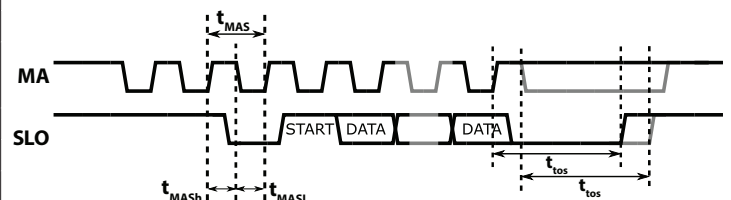

## Signals SSI

signals	clock (MA+, MA-) data (SLO+, SLO-)
multiturn	on special request; please contact our sales staff;
timeout $t_{tos}$	375-605 ns
permissible clock period $t_{MAS}$	up to 4 MHz (250 ns)
clock signal hi level duration $t_{MASH}$	125 ns up to timeout
clock signal lo level duration $t_{MASL}$	125 ns

Timing Diagram SSI

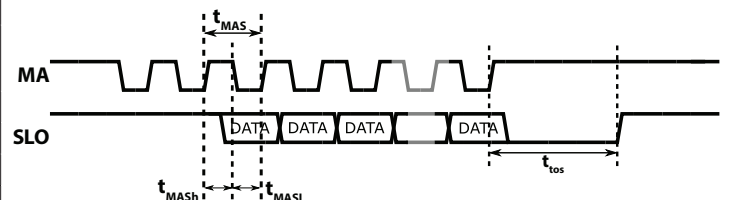

- follow standard ESD precautions
- turn power off before connecting the sensor.
- do not touch the electrical pins without static protection such as a grounded wrist strap

## Orientation Options

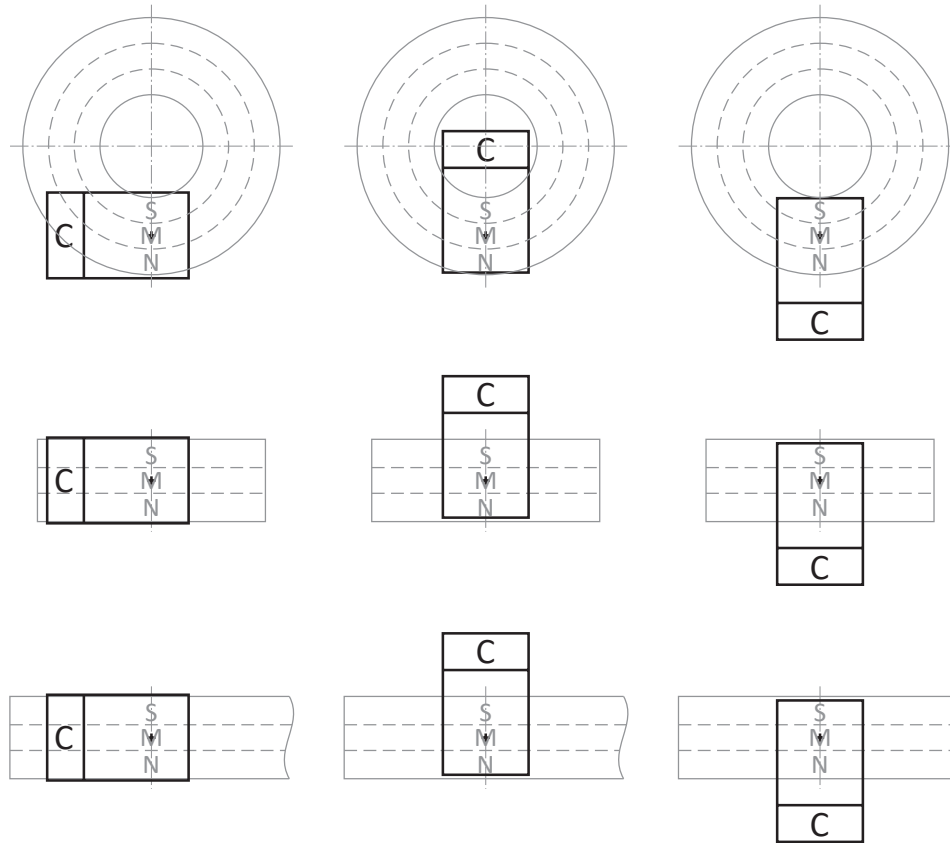

## Pin Assignment

pin no.	output signals depending on selected interface incremental (D-parameter)			
	D2 - ABZ	D3 - UVW	D4 - STEP	D5 - CW/CCW
1	/Z	/W	/NCLR	/NCLR
2	Z	W	NCLR	NCLR
3	/B	/V	DIR	/CCW
4	SLO-	SLO-	SLO-	SLO-
5	SLO+	SLO+	SLO+	SLO+
6	V-	V-	V-	V-
7	V+	V+	V+	V+
8	MA-	MA-	MA-	MA-
9	MA+	MA+	MA+	MA+
10	B	V	DIR	CCW
11	/A	/U	/STEP	/CW
12	A	U	STEP	CW

**Connector C1**

Molex 501568-1207; 12 pin male connector; mating cycles: 30

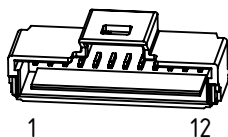

**Connector C3**

FFC (12 pin, 0.5 mm pitch); mating cycles: 20

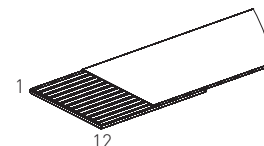

## Dimensions for C1 (1.28 and 1.50 mm Pole Pitch, Molex Connector)

01 (0°)

02 (90°)

04 (270°)

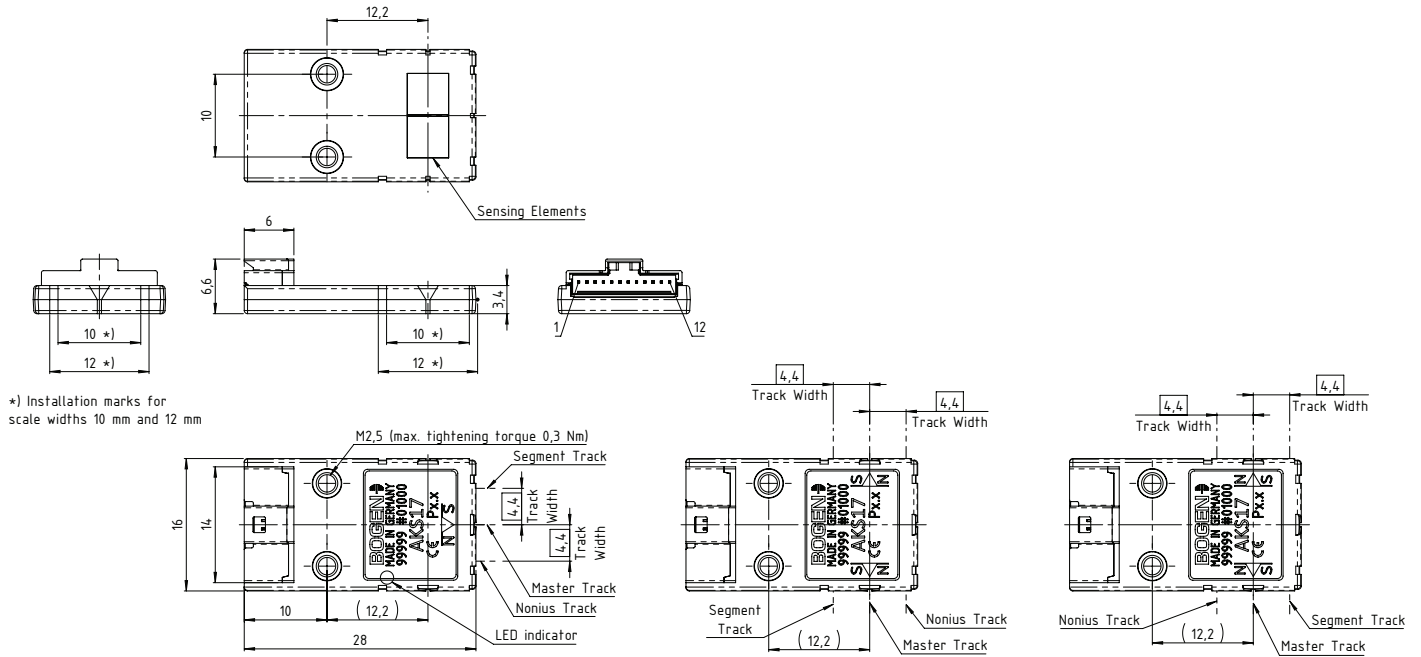

## Dimensions for C3 (1.28 and 1.50 mm Pole Pitch, FFC Connector)

01 (0°)

02 (90°)

04 (270°)

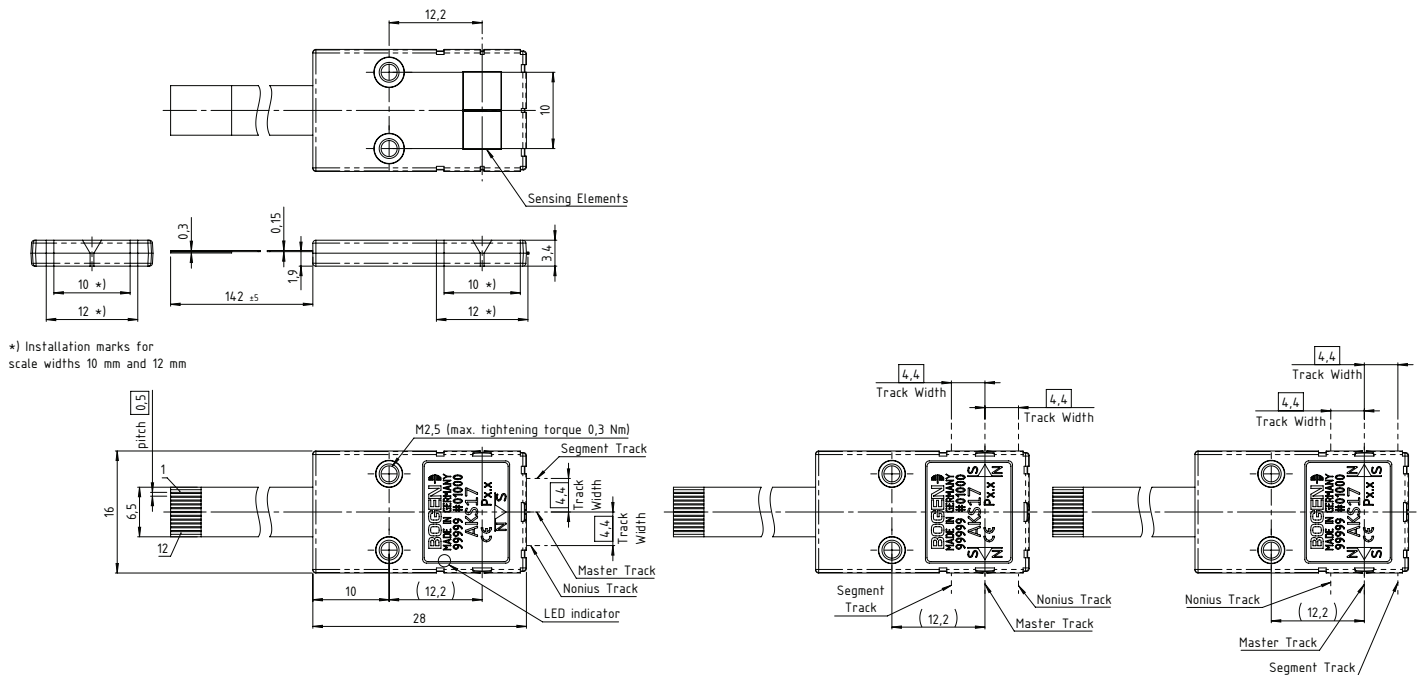

## Calibration

Each AKS17 requires a calibration process in the final assembled state. It is recommended that the calibration is performed across the whole working range/measuring length of the magnetic scale. The calibration process consists of an analogue calibration, where the different sensors in the sensing head are being optimized for best performance and a nonius calibration where the sensing head is optimized over the scale/measuring length. With the programming software and hardware the parameters of an AKS17 sensing head can be adapted for a successful calibration. The software sets the sensing head parameters for the correct master-nonius-segment periods (128-127-120, 256-255-240, 512-511-496, 1024-1023-992), the operating measurement systems (linear, rotary radial, rotary axial) and the interface absolute and incremental.

## Installation Tolerances

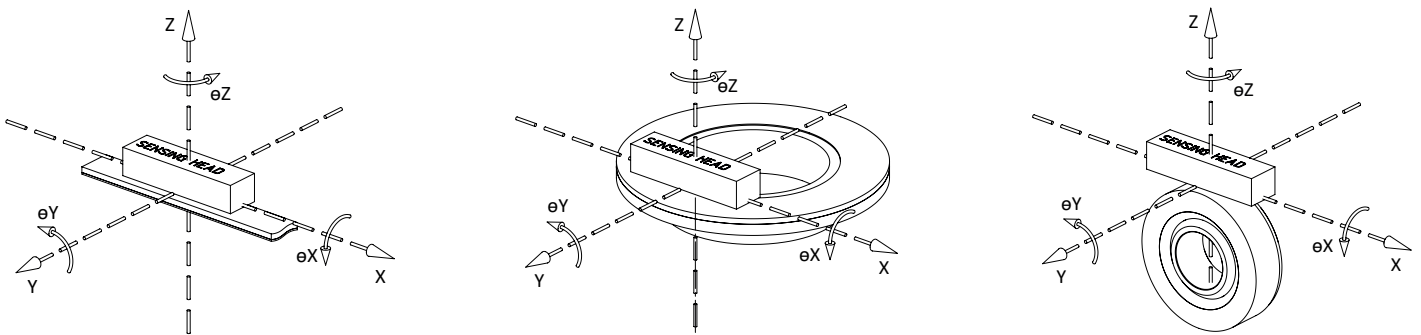

## Assembly Values and Tolerances

Z [mm]	for 1.28 mm pole pitch: 0.4 mm ± 0.05 for 1.50 mm pole pitch: 0.5 mm ± 0.05 for 2.00 mm pole pitch: 0.6 mm ± 0.05
X [mm]	±0.5
Y [mm]	±0.5
$\theta Z$ [°]	±1
$\theta X$ [°]	±1
$\theta Y$ [°]	±1

## Order Code

### AKS17 - O - P - C - H

			code <sup>(1)</sup>	explanation <sup>(1)</sup>
parameter	O	orientation option	<b>O1</b>	<b>angular position to the scale: 0°</b>
			O2	angular position to the scale: 90°
			O4	angular position to the scale: 270°
	P	pole pitch [mm]	<b>P1.28</b>	<b>1.28 mm</b>
			P1.50	1.50 mm
			P2.00	2.00 mm
	C	connector	<b>C1</b>	<b>Molex 12 pin</b>
			C3.142	FFC 12 pin, 0.5 mm pitch, length 142 mm <sup>(2)</sup>
	H	interface	<b>H0<sup>(3)</sup></b>	<b>without linedriver</b>
			H1	with linedriver

<sup>(1)</sup> standard parameters are bold

<sup>(2)</sup> standard lengths, other lengths on request

<sup>(3)</sup> for this linedriver option only absolute interfaces are available

## Ordering Examples

AKS17-01-P1.28-C1-H0	AKS17 magnetic sensing head, orientation option parallel, 1.28 mm pole pitch, connector, Molex 12 pin, without linedriver
AKS17-02-P1.50-C1-H1	AKS17 magnetic sensing head, orientation option perpendicular, 1.50 mm pole pitch, connector Molex 12 pin, with linedriver
AKS17-01-P1.28-C3.142-H0	AKS17 magnetic sensing head, orientation option parallel, 1.28 mm pole pitch, connector 12 pin FFC, 0.5 mm pitch, length 142 mm, without linedriver

## Customer-Programmable Parameters<sup>(4)</sup>

		code <sup>(5)</sup>	explanation <sup>(5)</sup>
parameters	size	Z1	16/15 nonius
		<b>Z2</b>	<b>32/31 nonius</b>
		Z3	64/63 nonius
	absolute interface	<b>A1</b>	<b>BiSS</b>
		A2	SSI
	incremental interface	<b>D1</b>	<b>none (available for linedriver options H0 and H1)</b>
		D2 <C>	ABZ <C> counts of scale, value between 4 and 262144 in steps of 4, default is 16384 (available for linedriver option H1 only)
		D3	BLDC motor commutation (UVW) (on request, available for linedriver option H1 only)
		D4	step / direction (on request, available for linedriver option H1 only)
		D5	CW / CCW incremental (on request, available for linedriver option H1 only)

<sup>(4)</sup> parameters have to be set by customer before calibration; programmable with programming unit (order no. 55040).

<sup>(5)</sup> preset parameters are bold

## Ordering Examples

AKS17-01-P1.5-C1-H0-Z1-A2-D1	AKS17 Magnetic Sensing Head, orientation option parallel, 1.5 mm pole pitch, connector Molex 12 pin, without linedriver, 16/15 nonius, SSI, no incremental interface
AKS17-01-P1.5-C1-H1-Z2-A1-D2.16384	AKS17 Magnetic Sensing Head, orientation option parallel, 1.50 mm pole pitch, connector Molex 12 pin, with linedriver, 32/31 nonius, BiSS, ABZ 16384 steps

## Required Accessories

	programming unit (55030)*	programming unit (55040)**
for AKS17 with C1 connector	X	
for AKS17 with C3 connector		X

\*) includes programming adapter (52039), USB connector cable (53016), adapter cable Molex C1 (58276) and magnetic viewer

\*\*) includes programming adapter (52039), USB connector cable (53016), adapter PCB (55028) and magnetic viewer; please note: sensor is equipped with FFC cable, no additional adapter cable required

## Corresponding Linear and Rotary Magnetic Scales

BOGEN offers a comprehensive scope of standard and tailor-made scales in a variety of sizes and accuracy classes. For more information on our standard linear and rotary magnetic scales, please refer to our dedicated datasheets.

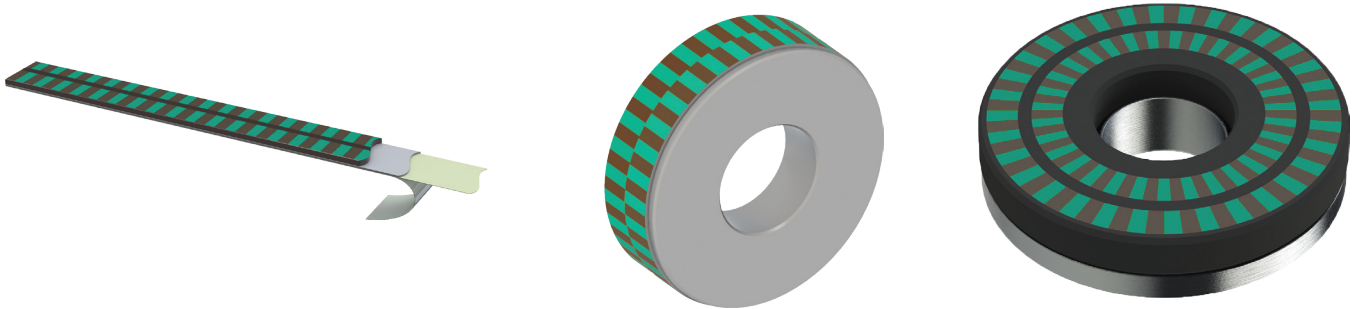

BOGEN Magnetics GmbH reserves the right to make changes, without notice, in the products, including software, described or contained herein in order to improve design and/or performance. Information in this document is believed to be accurate and reliable. However, BOGEN Magnetics GmbH does not give any representations or warranties, expressed or implied, as to the accuracy or completeness of such information and shall have no liability for the consequences of use of such information. BOGEN Magnetics GmbH takes no responsibility for the content in this document if provided by an information source outside of BOGEN products. In no event shall BOGEN Magnetics GmbH be liable for any indirect, incidental, punitive, special or consequential damages (including but not limited to lost profits, lost savings, business interruption, costs related to the removal or replacement of any products or rework charges) irrespective the legal base the claims are based on, including but not limited to tort (including negligence), warranty, breach of contract, equity or any other legal theory. Notwithstanding any damages that customer might incur for any reason whatsoever, BOGEN product aggregate and cumulative liability towards customer for the products described herein shall be limited in accordance with the General Terms and Conditions of Sale of BOGEN Magnetics GmbH. Nothing in this document may be interpreted or construed as an offer to sell products that is open for acceptance or the grant, conveyance or implication of any license under any copyrights, patents or other industrial or intellectual property rights. Unless otherwise agreed upon in an individual agreement BOGEN products sold are subject to the General Terms and Conditions of Sales as published at [www.bogen-magnetics.com](http://www.bogen-magnetics.com).



## AKS17

### Absolute Magnetic Sensing Head

## INSTALLATION AND OPERATION INSTRUCTIONS

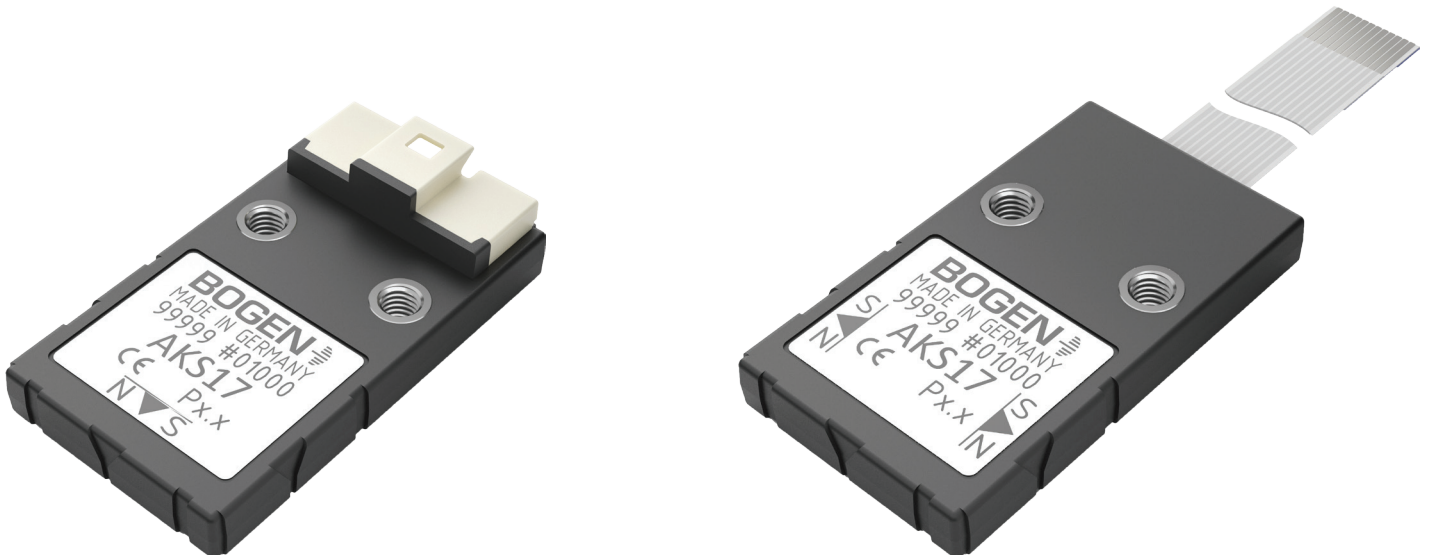

## Safety Instruction

Read these instructions carefully prior to installation and operation.

This manual is intended for professionals who perform the installation and the setup. The assembly of the system requires knowledge of mechatronics and general health and safety regulations.

Follow all warnings and instructions for your own safety and the safety of your system.

These operating instructions apply to the incremental magnetic sensing head AKS16 in connection with a magnetic scale for linear or rotary applications.



### **Risk of electric shock or short circuit!**

Incorrect handling of electrical equipment can be fatal or cause damage to property.



### **Danger to life!**

Unauthorized use of the system can be highly dangerous.

The magnetic position sensing heads must not be used in life-saving systems such as airplanes etc.



### **Risk of pinching**

There is a risk of getting pinched between the sensing head and the magnetic tape. This can lead to injury or mechanical damage. Avoid getting with your limbs and tools near the gap between the head and the tape while the measuring system is in motion!



### **Dangers that may follow**

Malfunctions of the measuring system can lead to further risks to the device or the system in which it is embedded. When there is evidence that the measuring system is not working properly, it must be put out of operation and secured against unauthorized use. The prescribed safety regulations must be observed for the use of position sensing heads. In particular, measures must be taken to prevent dangers to people and property in the event of a failure. This includes the installation of additional safety limit switches, emergency stop switches and the observance of the required environmental conditions



### **Risk of damage for the magnetic layer**

Magnetic tapes and sensing heads can be damaged by magnetic fields!

Apply only demagnetized tools for assembly and maintenance!

Improper storage of magnetic tape rolls can lead to magnetic interaction between the layers and thus to a reduction of the measurement accuracy

## Electromagnetic Compatibility

For the electrical connection it is essential that the electromagnetic compatibility (EMC) is guaranteed.

- System and control cabinet must be connected to the same ground potential.
- Use shielded cables. Connect the cabinet side of the cable shield with protective earth (PE).
- Avoid installing in close proximity to power lines.
- The nominal operating voltage (see datasheet) must be observed even if there is a voltage drop along the supply line!
- Determine the place of installation so that inductive and capacitive interferences cannot affect the sensor. By adequately routing the cable, interferences can be reduced.

## Intended Use

The magnetic position sensing heads AKS17 are highly accurate measuring devices consisting of magnetic scales and sensing heads capable of non-contact position detection for linear and rotary applications.

## Fields of Deployment

- capital equipment,
- automation,
- medical engineering,
- electrical engineering.

A measurement solution consists of a sensing head and a linear or rotary magnetic scale and can be incorporated into various electronic systems. It can be configured according to the customer's specifications. In combination with a suitable analysis software absolute and relative position and position changes can be measured. In this way it is possible, for instance, to control machine tools, determine torsional forces or detect longitudinal expansions.

## Function and Properties

The magnetic position sensing heads AKS17 are suitable for non-contact, absolute and incremental position measuring systems. The measuring function is realized by magnetic scanning.

The system has the following features:

- absolute and incremental encoder
- 21 to 24 bit absolute resolution
- 18 bit incremental resolution
- non-contact, quick position measurement

- single piece unit
- no wear from usage
- resistant to dust, cooling lubricant emulsion, oil, etc.
- different diameters and length offered
- radial, axial or linear reading.

## Mode of Operation

The sensing head with its sensor is mounted on the machine part whose position is to be measured. The measuring magnetic surface is mounted along the measuring distance. On the magnetic tape alternating magnetic north and south poles are positioned with a regular distance. The magnetic hall sensor cells in the sensing head are scanning the magnetic poles on the tape contact-free. Permissive linear and rotation speed see technical data sheet of the respective type on our website.

## Digital Absolute Output

The sensing head with digital absolute output signal converts the analog signals to an absolute information in BISS-C or SSI.

## Digital Incremental Output

The sensing head with digital incremental output signal converts the analogue signals into digital A/B and Z pulses and transmits them to the controller. The two digital signals A and B are electrically phase-shifted by 90°. The sign of the phase shift represents the direction of movement of the sensor. Every change of A or B (rise to fall or vice versa) is a count for the period counter (up/down counter). If signal A is preceding signal B, the counter increases. If signal B is preceding signal A, the counter decreases. The Z pulse appears every time when passing the zero point. The controller thus knows at all times the increment position, without having to query the sensing head periodically (real-time capability). Therefore, after an interruption of the power supply the sensing head can still read its correct absolute position on the scale.

## Assembly and Installation

During assembly utmost cleanliness is required. Device parts have to be degreased thoroughly before gluing.

During installation the mounting tolerances and the position of the measuring point have to be observed respectively implemented as stated in the datasheet.

## Measurement Options

The AKS17 comes with two measurement options.

- option 1 is a sensing head with parallel orientation of AKS17 chip
- option 2 is a sensing head with perpendicular orientation of AKS17 chip

## Delivery Condition

The AKS17 is supplied with a connector Molex 501568-1207 or with a FFC as an alternative for Molex.

## Programming Device

### Introduction

Each AKS17 requires a calibration process in assembly. It is recommended that the calibration is performed across the whole working range of the sensing solution.

The calibration process consists of an analog calibration where the different sensors in the sensing head will be optimized for best performance and a nonius calibration where the sensing head is optimized over the scale.

With the AKS17 software and hardware the parameters of an AKS17 sensing head can be changed for a successful calibration. The software sets the sensing head parameters for the correct master-nonius periods (128/127/120, 256/255/240, 512/511/496, 1024/1023/992) and the operating measurement systems (linear, rotary radial, rotary axial).

To calibrate the sensing head you need:



Windows PC



cable for programming unit  
(USB 2.0 type A connector/ mini-B connector)



AKS17  
programming unit



cable (9 pin serial cable/ Molex or FFC)

## System Requirements

The programming device can be connected to a Windows PC with a USB cable and operated with the dedicated software. The software requires Windows Vista or later (32/64 Bit).

Before the programming device (programmer AKS17) can be connected the specific driver must be installed. Copy the software to a local directory on your Windows PC. To install the driver execute the specific program USB\_Adapter\_00052040\_Driver.exe Connecting the device (for calibration setup)

Mount the sensing head correctly per mechanical specifications. It is required to place the sensing head within the allowed mechanical tolerances (maximum displacement), see technical data sheet. Both status LEDs (green and red) on the AKS17 sensing head will light up now if all devices are mounted correctly. The pictures below show the final stage of all connected cables and the programming device.



## Programming Software

Copy the programming software (AKS16 and AKS17 Calibration GUI) to a local directory or use the “Setup.msi” to install the software and the driver. By default the installation directory can be found at “Program Files”.

## Configuring AKS17 Sensing Head

The software will calibrate the sensing head for the present mechanical alignment. Make sure the AKS17 sensing head is now mounted correctly including all devices for calibration. Ensure, that the AKS17 is connected to the PC as described above.



Start the BOGEN calibration software "AKS16 and AKS17 CalibrationGUI".

Choose "AKS17" from the "Sensor" combo box.

Choose the desired sensor parameters (see technical data sheet for full listing of sensor parameters). Please note that the resolution combo box is only available if interface incremental is "ABZ" which describes the incremental ABZ resolution. When "UWV" is chosen another combo box will appear. Here the user can choose the pole pairs that correspond to UWV (see datasheet). Choose the orientation option from the right side of the window by clicking on the photo or the radio button. Make sure it is how the sensor is mounted.

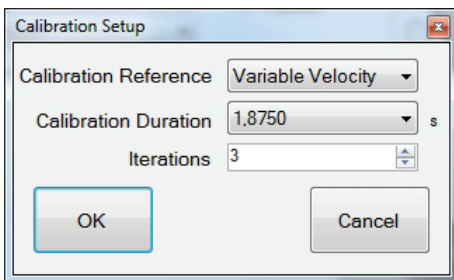

From "File" in the main menu the sub menu items "Calibration Setup" and "Preference" can be reached. These configurations are set by default as seen in the figures and they will be saved and reused every time the program starts. For a detailed description please refer to "Tips on the software and calibration".

Connect the sensor to the adapter and then the adapter to the PC. Please make sure the sensor is mounted properly within the tolerance (see datasheet).

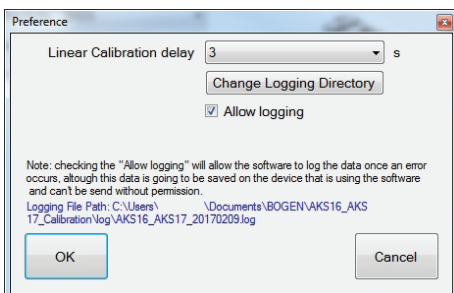

In case of radial or axial orientation start rotating the scale (or move the sensor around the scale) and press "One step calibration".

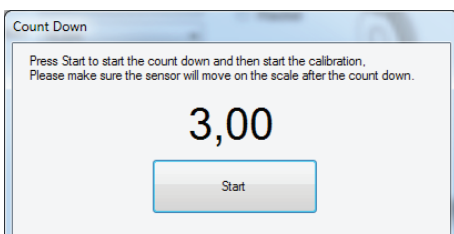

In case of linear orientation make sure the sensor will start moving after the delay, then press "Start".

Note: The user should just move the sensor manually at the end of the delay countdown.

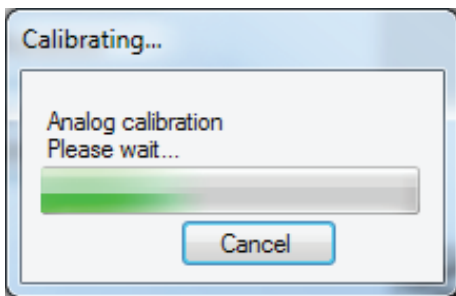

Afterwards the program starts the automatic calibration operation and interacts and shows the user the current process.

In analog calibration the user will be prompted to adjust the current X-Y-position or to verify the air gap between the sensor and the scale or both if needed. In case of linear calibration the user will be prompted with the countdown window on every iteration.

The user has to move the magnetic target during the calibration process. In linear application the user can move the scale in a user-defined direction after the countdown is over. The duration of the movement depends on the "Calibration Setup".

Depending on the result of the analog calibration the user has the choice to repeat the calibration or to continue without adjusting the current position (not recommended but possible).

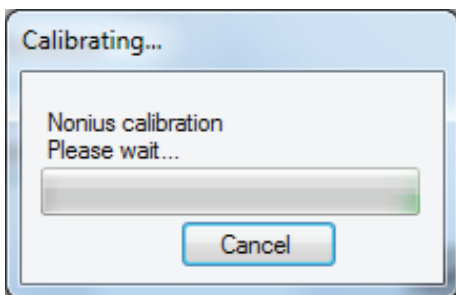

The next step is the nonius calibration where the sensor uses the calibrated analog parameters to read out the sensor. If the read out results contain values that are out of range, the calibration considered to be failed and has to be done again. In case of linear calibration the user will be prompted with a count down window on the nonius calibration.

The user can continue and save in case of bad nonius calibration (not recommended but available for extreme situations).

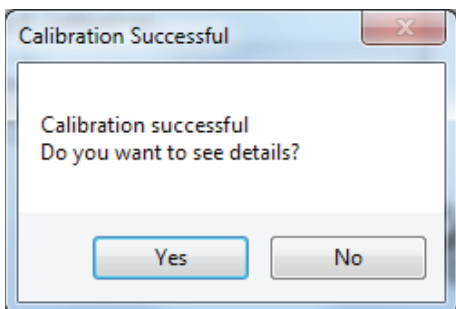

If the calibration has been successful the user will be informed about this. Now the user has the choice if he wants to see details or not. The details contain several calibration charts as seen on page 8.

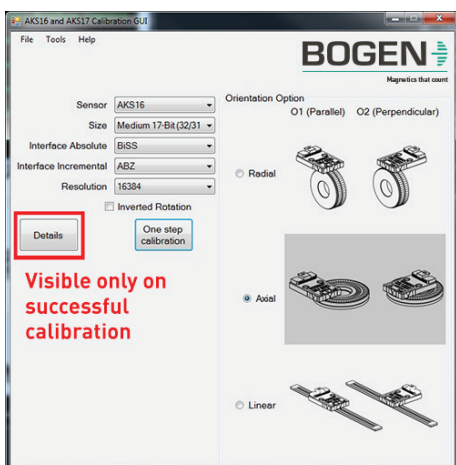

A "Details" button will be visible after calibration is finished. After pressing this button a new window will be shown. It contains all calibration information details (for more information on details please refer to "Details" section).

Disconnect the cables from the PC, programmer AKS17 and sensing head. The sensing head is now ready for use. Connect the sensing head with your devices or power unit as desired for your application.



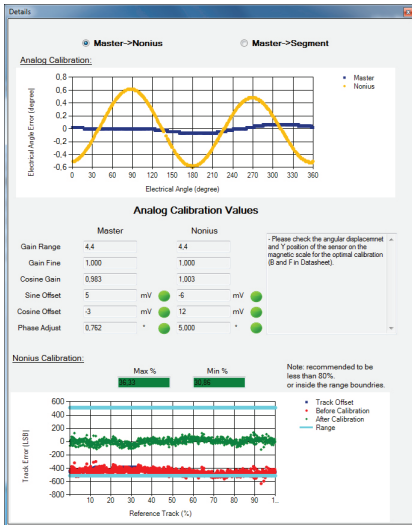

In the "Details" window the user can check the calibration charts and calibrated analog values. The "Details" window consists of three sections:

### 1. Analog calibrations

A good calibration should center both graphs, Master and Nonius, as close as possible to zero. The smaller the amplitude, the better the calibration. In case the analog electrical angle error is more than 12° the analog calibration is considered to be failed.

### 2. Analog calibration values

Analog calibration values are automatically calculated and set in the sensor. The user cannot change them but he can read them for verification purpose. A green circle next to the value means that the value is within the recommended range. Otherwise the circle is red and in the textbox to the right the user can see the corresponding error message.

### 3. Nonius calibration

Max% and Min% represent the maximum and minimum percentage value from result regarding the range. If marked green, they are less than 80% of the range. If marked orange, they are between 80% and 100%. Otherwise the mark is red. It is recommended to keep them less than 80% of the range. A better calibration has values of "Result", "Error" and "Track" closer to zero.

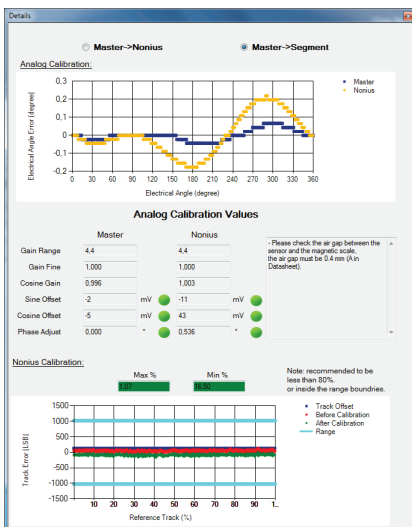

## Protocol Data Packet Information

The protocol data packet can be shown by connecting the sensor and then clicking on "Help" in the menu. After clicking on "Show Protocol Data Packet" the currently saved internal protocol configuration that has been set inside the sensor in both BiSS and SSI protocols will be shown.

The following two figures are examples of BiSS-C and SSI protocol packets

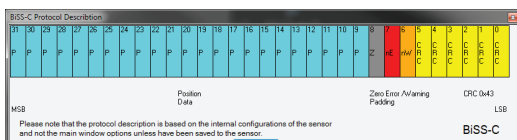

AKS17 23-Bit BiSS-C data packet information example. Note that the red nE and the orange nW are active low bits.

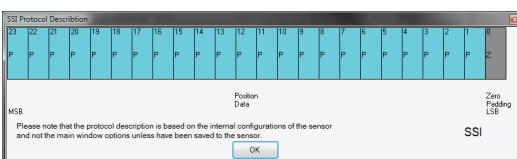

AKS17 23-Bit SSI data packet information example.

## Offset Compensation

The software provides an “offset compensation” tool which can be accessed via the “tools” menu. It offers two options:

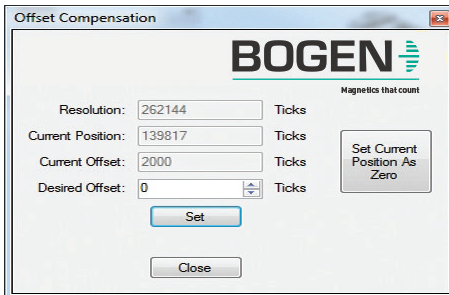

- the user can set the current position to zero. In this case the software will calculate the offset needed to set the current position as zero automatically, or
- the user can set the desired offset manually. The new current position is calculated by adding the offset to the current position.

Example: Current position is 24000 Ticks but the user wants this position to be 1050 Ticks. Now the user can enter 239194  $((\text{Current Position} + \text{Resolution}) \bmod \text{Resolution})$  in the “Desired Offset” and then click “Set”. The software automatically calculates the smallest possible offset that is a multiple of 4 and more than the desired offset, that is 239196 to be set.

## Serial Port Signal Trigger

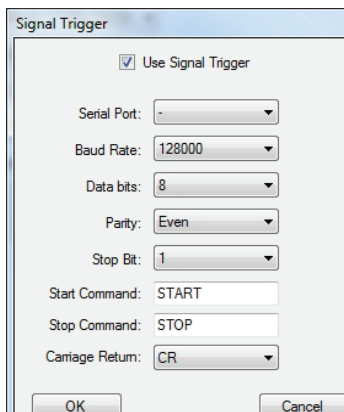

The software provides a triggering signal using the serial port. The typical application for this feature will use a microcontroller with already defined commands to start and stop. This microcontroller passes the signal to a more complex system, e.g. starting a motor.

In this window the user needs to set the corresponding configurations for the signal receiver and the “Start/Stop” commands. If a carriage return is chosen it will automatically be amended after the command.

**Note: this tool is meant to be used only by professionals! Please provide an appropriate safety mechanism, including emergency switches, movement limit switches etc.**

## Tips on the Software and Calibration

- For radial and axial orientation it is recommended to use constant velocity as much as possible and the calibration duration should cover at least 4 pole pairs.
- For linear calibration the sensor should at least cover four pole pairs. The user can use the “Calibration Duration” to cover the desired measuring area.
- Linear calibration delay is a user preference. It can be chosen as desired to provide time before the calibration starts. This delay can be helpful to make sure that the sensor starts moving at the end of the delay.
- The “Iteration” parameter is for analog and nonius calibration where more than one calibration is recommended and the default is three iterations.
- A backup of the sensor parameters can be saved on the PC by clicking “File” and after that “Save Config”. Later the user can use this backup for reprogramming the sensor with the same parameters. Therefore the user has to click on “File” and then on “Load Config”.  
Note: The sensor should be connected to the PC before saving or loading configurations.
- The connected sensor serial number, the product order code and parameter descriptions can be found under “Help”, then “Product Information”. Note: The sensor should be connected before retrieving the product information.
- If you are facing a problem then please make sure that Logging is allowed by verifying the check box. Follow the path “File”, “Preference” and activate “Allow Logging”. Then click on “Help” and “Send Report” where you can enter a short description of your problem. We will process your inquiry as soon as we get it.  
Note: This report will be sent by using your local Outlook account. If this is not possible then an instruction will be shown.

## Commissioning

After mounting the distance measuring system or after replacing the sensing head, verify general system operation as follows:

- recalibrate the sensing head,
- switch on the supply voltage of the sensing head,
- move the sensing head along the entire measurement path or revolution,
- check that all signals are present at the output,
- check if the count direction matches the traversing/revolution direction. If this is not the case please mark the checkbox in the main window of the software.

## Maintenance

The functionality of the measuring system and all related components must be reviewed and recorded regularly. For more information and data sheets please visit our website: [www.bogen-magnetics.com](http://www.bogen-magnetics.com)

## Appendix

### Troubleshooting

If there are signs of interference or malfunctioning, the measurement system must be put out of operation and secured against unauthorized use.

### FAQs

Q: Can I connect a sensor after I have chosen my desired sensor parameters?

A: Yes, in case the user wants to choose the parameters first and then calibrate the sensor the software will allow this order.

Q: Can I connect a different sensor after I have calibrated the first sensor?

A: Yes, the software has been developed to perform this scenario. The software will disconnect the sensor automatically after performing a calibration. The user can freely disconnect the cables and reconnect a new sensor if desired.

Q: How can I choose calibration duration?

A: Calibration duration represents a time variable. The duration should cover at least four pole pairs for successful calibration.

Example: If the AKS17 is used with a 1.28 mm Pole Pitch Linear Scale then four pole pairs are  $8 * 1.28 = 10.24$  mm. This is the absolute minimum calibration distance. If the sensor is moving along the scale with a speed of 5 mm per second, then the calibration duration is  $\text{distance} / \text{speed} = 10.24 / 5 = 2.048$  seconds. Thus we choose the nearest bigger calibration duration available in the given parameters, that is 2.1875 seconds.

Q: Can I connect a sensing head for 1.28 mm and 1.5 mm pole pitch with the same programming unit and software?

A: Yes. The software recognizes the different pole pitches and performs the right actions. The programming unit can handle both pole pitches.

Q: Can I connect an AKS16 and AKS17 with the same programming unit/software?

A: The programming unit and the software are able to work with both sensing heads.

Fault / Error Message	Possible cause	Measures
Could not connect the sensor. Failed communication to BiSS master, check the connected interface.	Cables are not connected correctly.	Please check the cables to the adapter and to the sensor.
	Another program maybe using the adapter.	Please close any other application that may use the adapter. If the problem still exists perform a PC restart.
Could not connect the sensor. BiSS communication failed. Check wire connection and power supply.	Another program maybe using the adapter.	Please close any other application that may use the adapter. If the problem still exists perform a PC restart.
	Not enough power supply for the adapter.	Please make sure that the PC can provide enough power on the USB port. If not, you have to provide external power.
	Contacts are poorly shielded.	Use shielded cables and ensure proper contacting.
Install FTDI interface driver.	The adapter driver is not installed.	Please install the corresponding driver to your adapter. If the problem still exists a restart maybe necessary.
Calibration failed, rotation speed is too slow for calibration.	Velocity or duration are not high enough.	Increase velocity or calibration duration.
Calibration failed, rotation speed is too fast for calibration.	Velocity or duration exceed the limits.	Decrease velocity or calibration duration.
Calibration succesful but rotation speed is too slow to acquire one complete turn.	A full scale calibration was not performed.	This warning can be ignored when the user is not using the full scale measurement area. Otherwise it is recommended to repeat the calibration with higher velocity or higher duration and cover all the scale.
Calibration failed, invalid calibration data cycle count.	Very noisy environment.	Please make sure that the cables are shielded and that there is no interference in your application.
	The magnetic poles are damaged in some places.	Replace the magnetic nonius scale.
Please check the air gap between the sensor and the magnetic scale. The air gap must be 0.4 mm. Please check X, Y position of the sensor on the magnetic scale or the optimum calibration.	The sensor position is out of tolerance.	Please verify the air gap and X, Y mechanical position of the sensor to match the tolerance discussed in installation tolerance.
	The sensor position is out of tolerance.	Please verify the air gap and X, Y mechanical position of the sensor to match the tolerance discussed in installation tolerance.
Nonius calibration failed. Please reposition the sensor and press "Retry".	Very noisy environment.	Make sure that the cables are shielded and that there is no interference in your application.
	The magnetic poles of the scale are damaged in some places.	Replace the magnetic nonius scale.
Could not connect the sensor. Unable to detect the slave. Please connect compatible AKS17.	Wrong sensor.	Make sure that the sensor option matches your sensor.
Analog parameters are all 0 and in the error textbox you have the following message: "The analog electrical phase error is very big. Please check the current sensor configurations and positions."	The sensor is badly positioned. The software and the sensor cannot calibrate this big error.	Reposition the sensor according to the datasheet.
		Make sure that the master mark on the sensor is aligned with the master track on the ring.
You have good analog calibration but bad nonius calibration.	Wrongly aligned sensor to the ring.	Make sure that the master mark on the sensor is aligned with the master track on the ring.
	Wrong ring size.	Make sure that the ring matches the "Size" parameter.

## EU Declaration of Conformity

According to EU regulation for Electromagnetic Compatibility 2004/108/EU and European Standard for Electromagnetic Compatibility EN 61326-1:2006 (EMC)

BOGEN Magnetics GmbH, Potsdamer Str. 12-13, 14163 Berlin, Germany

declares that

Magnetic Sensing Head Type: AKS17, Years of manufacture: since 2015

complies with the above-mentioned regulations and standards.

BOGEN Magnetics GmbH reserves the right to make changes, without notice, in the products, including software, described or contained herein in order to improve design and/or performance. Information in this document is believed to be accurate and reliable. However, BOGEN Magnetics GmbH does not give any representations or warranties, expressed or implied, as to the accuracy or completeness of such information and shall have no liability for the consequences of use of such information. BOGEN Magnetics GmbH takes no responsibility for the content in this document if provided by an information source outside of BOGEN products. In no event shall BOGEN Magnetics GmbH be liable for any indirect, incidental, punitive, special or consequential damages (including but not limited to lost profits, lost savings, business interruption, costs related to the removal or replacement of any products or rework charges) irrespective the legal base the claims are based on, including but not limited to tort (including negligence), warranty, breach of contract, equity or any other legal theory. Notwithstanding any damages that customer might incur for any reason whatsoever, BOGEN product aggregate and cumulative liability towards customer for the products described herein shall be limited in accordance with the General Terms and Conditions of Sale of BOGEN Magnetics GmbH. Nothing in this document may be interpreted or construed as an offer to sell products that is open for acceptance or the grant, conveyance or implication of any license under any copyrights, patents or other industrial or intellectual property rights. Unless otherwise agreed upon in an individual agreement BOGEN products sold are subject to the General Terms and Conditions of Sales as published at [www.bogen-magnetics.com](http://www.bogen-magnetics.com).