

Sensor Alignment with Small Diameter Rotary Scales

TN-1106 | REV 161007

PURPOSE

While MicroE optical encoders boast generous alignment tolerances for most applications, special care needs to be taken when aligning to small rotary scales with a diameter of 20mm or less.

BACKGROUND

The layout and geometries of linear and rotary grating patterns differ significantly which results in tighter alignment tolerances in some cases. See figures 1a and 1b below.

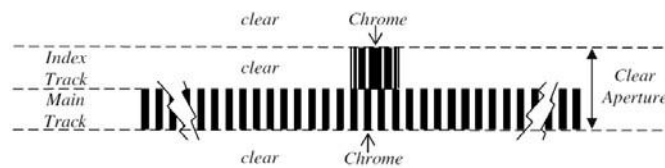

Figure 1a: Linear Grating Pattern Layout

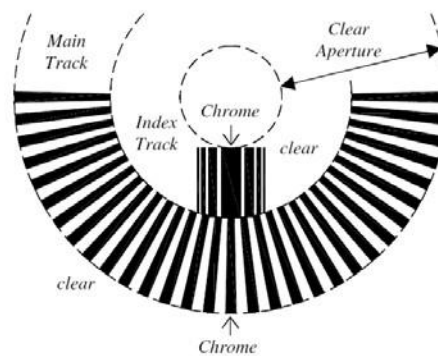

Figure 1b: Rotary Grating Pattern Layout

With rotary scales, the grating features are wedge shaped. They are thinner at the inside diameter and thicker at the outside diameter. This means the period of the lines and spaces change as the radius increases. At the nominal optical diameter, the period is exactly $20\mu\text{m}$. This is where the sensor must be positioned for optimum performance. Linear scales have lines that are straight and parallel so there is no change in period or modulation. For large diameter rotary scales, the period change is small and the encoder system will have the same alignment tolerances as a linear system. As diameters get smaller, the wedge shape of the main track lines becomes more pronounced. This will put greater restrictions on alignment in the radial direction.

General terminology for encoder alignment is defined as follows with X being the direction of travel along the scale, Y being the lateral direction to the left and right, and Z being the height or gap between the sensor and the scale. Theta X, Y or Z will be rotations about those axes. See figure 2 below.

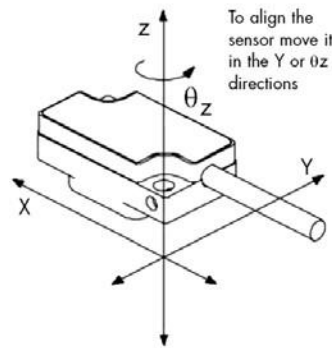

Figure 2: Sensor Orientation Axes

The Y direction is the axis that corresponds to the radial direction on a rotary scale. Alignment tolerance studies have been performed with linear and rotary scales to demonstrate the differences in acceptable Y misalignment. See Figure 3 below. This graph shows signal strength of the encoder sensor as a function of misalignment. Zero in the horizontal axis represents perfect, nominal alignment according to our interface drawings. The vertical axis is normalized sin/cos amplitude. Our specified alignment tolerance for a linear or large rotary grating is +/-200µm depicted below as vertical red dotted lines. This gives ample margin, as shown in the green trace, for additional misalignments in other axes or for the effects of thermal changes.

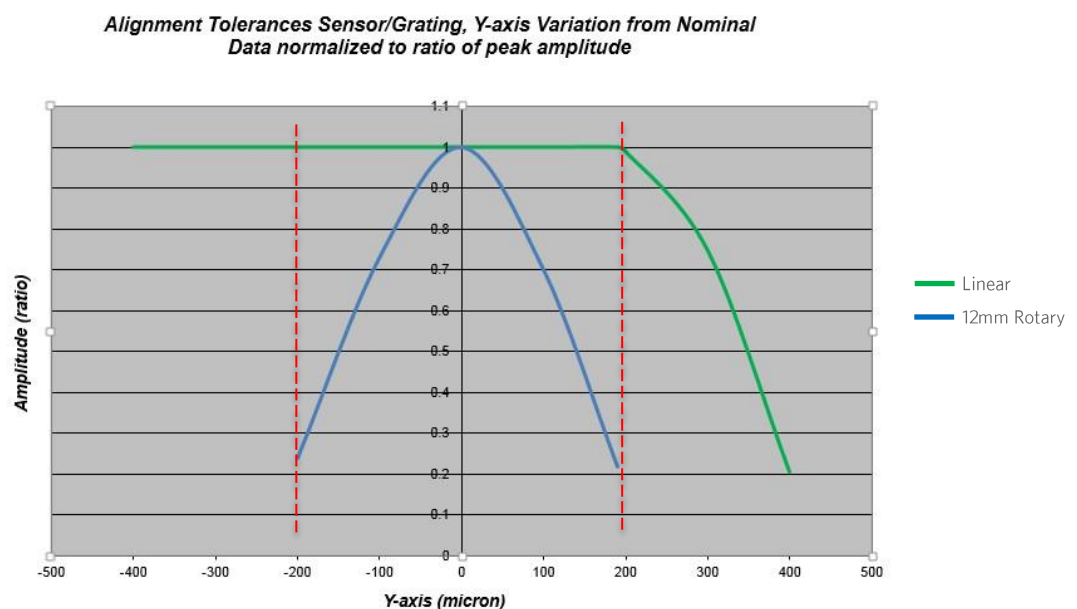

Figure 3: Y alignment tolerance study

The blue trace clearly shows how the sin/cos amplitude drops off far more abruptly for our standard 12mm disk; model R1206. At +/-200 μ m, the signal amplitude has dropped to only 20% of the ideal.

In order to maintain suitable signal strength for accurate interpolation, the acceptable misalignment should be limited to +/-100 μ m or less.

CONCLUSION

When designing a mounting scheme for a MicroE encoder system, particularly one with a small diameter rotary scale, it is important to provide adequate adjustability to the encoder sensor head mount. This will enable fine adjustment to the sensor/scale orientation to compensate for inevitable tolerance stack-up issues. Relying on benching surfaces for small diameter rotary scales is not recommended.